Avances y perspectivas de la generación fotovoltaica y almacenamiento de la energía sola

Nuevas tecnologías Fotovoltaicas



Prof. Dr. Patricio Valdivia Lefort

- Director of Research Line Solar Electricity
Fraunhofer Chile Research Center for Solar Energy

- Professor at Electrical Engineering Dpt.

UTFSM

02-03-2018

Agenda

Solar Energy Research in Chile

- Solar Energy in Chile
- Fraunhofer Chile Research Center for Solar Energy
- Ongoing Solar Projects

New Photovoltaic Technologies

- AgroPV worldwide experiences
- Expected results
- Monitoring Sistem
- Results
- Conclusions



Professor at Electrical Engineering Department
UTFSM



 **Fraunhofer**
CHILE

Located in Santiago



 **Fraunhofer**
ISE
Freiburg, Germany

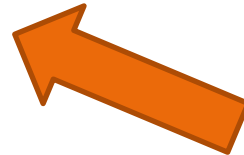

CORFO 

Fraunhofer Chile Research (FCR) Foundation Center for Solar Energy Technologies (CSET)

- Inauguration on May 27, 2015
- Center of Excellence, co-funded by CORFO
- Executing Partners:
Fraunhofer ISE, Germany,
Pontificia Universidad Católica de Chile
- Co-operation with important Solar Institutes and Initiatives in Chile (e.g. SERC)
- Application oriented R&D and Support
 1. Solar Electricity (PV, CPV, CSP)
 2. Solar Heat (Industrial Processes, Agriculture)
 4. Horizontal Integration (Building, Grid, Market,..)
- Adaptation of Technologies for Chile
- Quality Assurance, Standards and Certification (planned)



Fraunhofer Chile Research (FCR) Foundation Center for Solar Energy Technologies (CSET)

Scientific Progress

- 11 scientific papers published
- 3 scientific papers submitted
- 9 scientific conference published

Economic Progress

- 12 completed industry contracts
- 12 ongoing industry contracts
- 13 high priority industry leads
- 5 public funded contracts (508 kUS\$)

Several projects with participation of Fraunhofer ISE



Research Line 1 - Solar Electricity

1 Director + 4 researchers + 4 Engineers + 2 Technicians

- Photovoltaics and Concentrator Photovoltaics (PV & CPV)
- Concentrated Solar Thermal Power (CSP)
- High-temperature storage systems
- Electrical Grid and system analysis

Support of industry:

**Testing, Monitoring,
Simulation, Prefeasibility**

Adaptation of technology

Soiling investigations

Reliability and durability issues



Research Line 2 - Solar Heat

1 Director + 2 researchers + 2 Students

- Solar Process Heat
 - Mining
 - Agro- and Foodindustry
- Combined Heat and Power
- Energy Efficiency Measures

Our Support for Industry:

Feasibility studies, Simulation,
Support of new Business Models
Monitoring

Adaptation of technology
Reliability and durability issues



Business Development

Horizontal Activities

- Contacts with Industry in general
- Coordination of horizontal projects / integration of different areas
- Government - Strategic Initiatives - PES
 - Cuenca del Salado Solar
 - National Quality System

Support for Industry:

Grid Integration

Integration with other Sectors:

Buildings, Sustainable Construction

Economic Studies – Financial Modeling

Energy Market Analysis



Solar Energy Research in Chile

Solar Energy in Chile

enormous potential – high challenges

- Up to approx. 3.600 kWh/m² direct normal irradiation per year, more than any other place in the world
- North of Chile has the technical potential to supply all of Chile with clean solar electricity
+ even export electricity to neighboring countries
- Challenges: high UV, high temperature gradients, dust, salts, water scarcity,...
- Grid integration: Electricity storage and transport technologies will be most important
- R&D on “high radiation solar”
→ opportunity for Chile

Global Horizontal Irradiation (GHI)
Chile Mainlands



WORLD MAP OF GLOBAL HORIZONTAL IRRADIATION

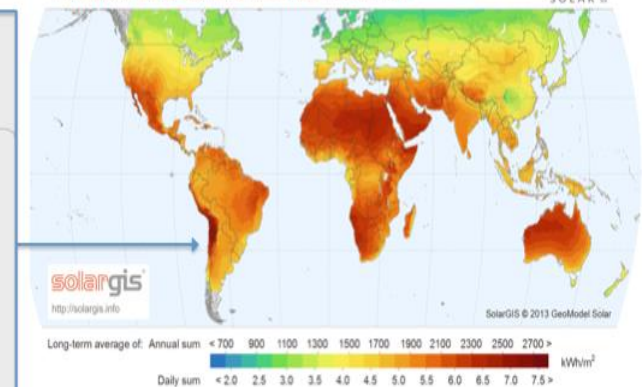

WORLD MAP OF DIRECT NORMAL IRRADIATION

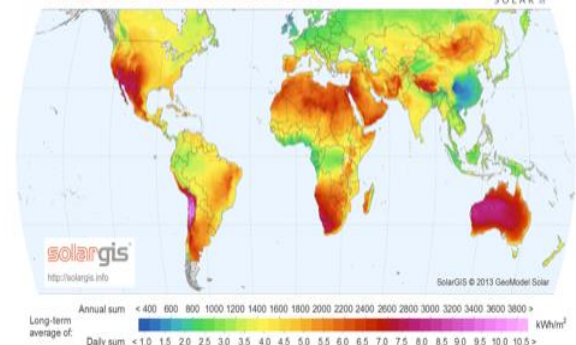

Ongoing projects

1.- Solar Resource Assessment

- Operation of state of the art meteo-stations
- Scientific analysis of ground based measurements
- Generation of time series based on satellite data



prerequisite for any project development

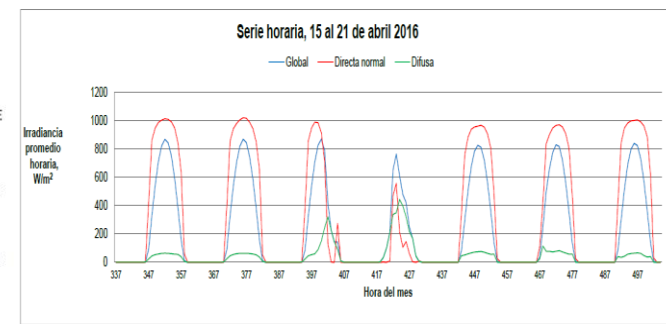
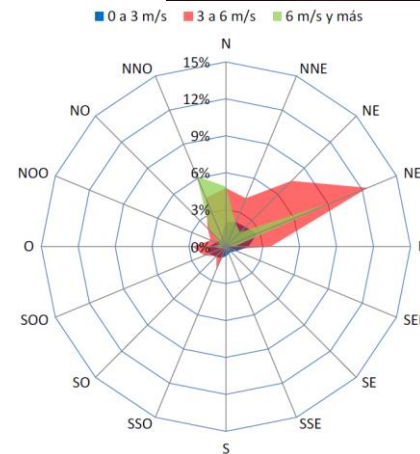
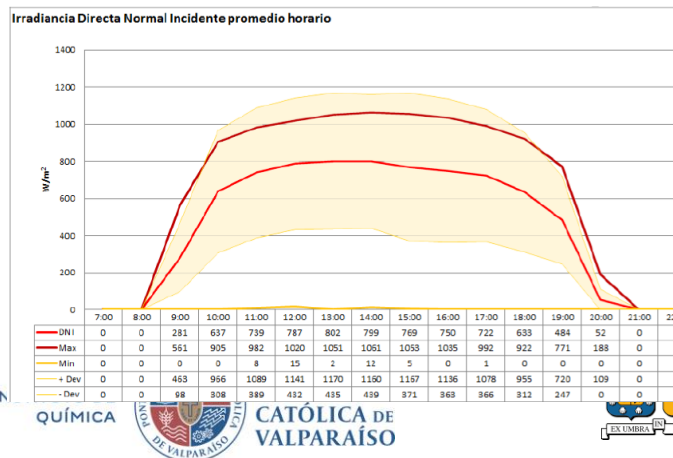

2.- Soiling effects on Concentrating Solar Power

- Soiling mainly affects plant performance.
- It is very important to know its behavior, because it affects Operation and Maintenance.
- The main factors affecting soiling are: reflector inclination, time of exposure and wavelength.

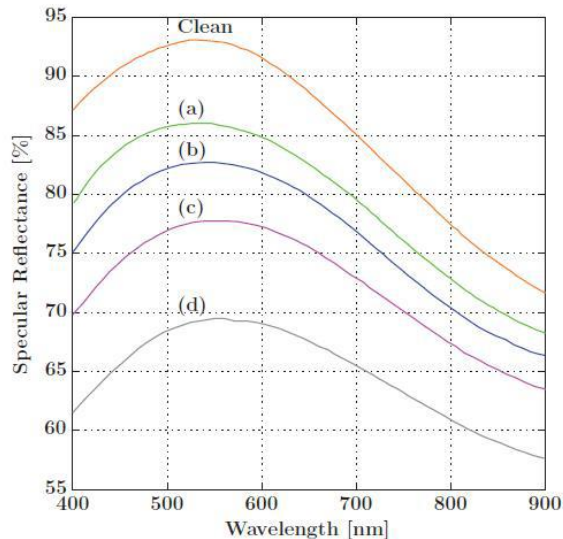
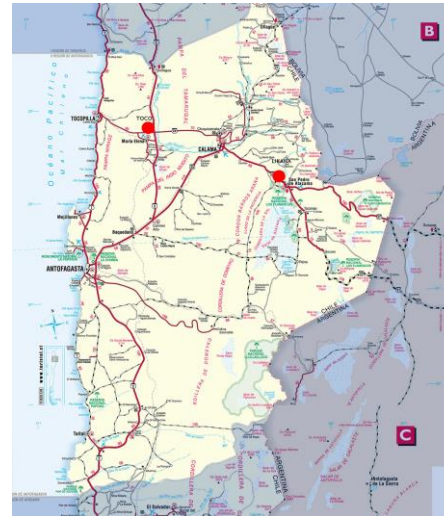

3. Soiling Analysis Project - PV Utility Scale Operator

Optimum management study of the cleaning of photovoltaic modules in plants in the Atacama Desert (400 + MWp capacity). The problem of fouling is a market of millions of dollars annually in Chile.

Optimum cash flow balance considers: Optimum cash flow balance considers:

- Historical fouling rates measured on land
- Commercial balance in the expected spot market
- Costs and durations of different cleaning technologies
- Entire linear optimization methodologies for 1-year horizon

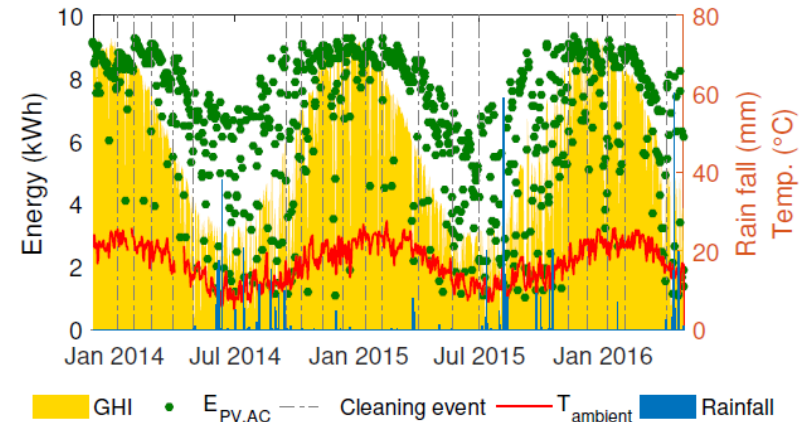
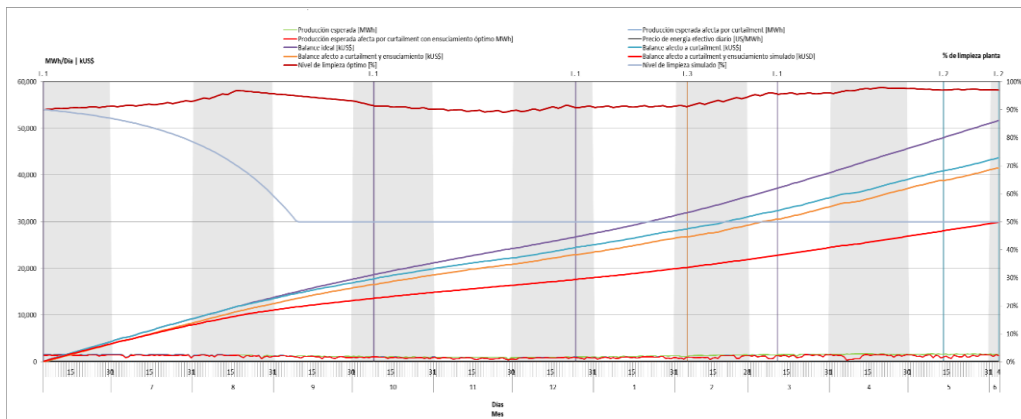

4.- Double Use of Land– Agriculture and Photovoltaics

Project Agro-PV

Public funding for further development of the Agro-PV concept for local plants and conditions in Chile, based on the experience of the German project

Main topics:

- Adapted cost **efficient construction of a PV plant above areas** used also for agricultural use (crops)
- Investigation of the **partial shading patterns by the PV-modules** on the plant growth and quality of the agricultural products
- 3 prototype plants for small and medium size agricultural farms

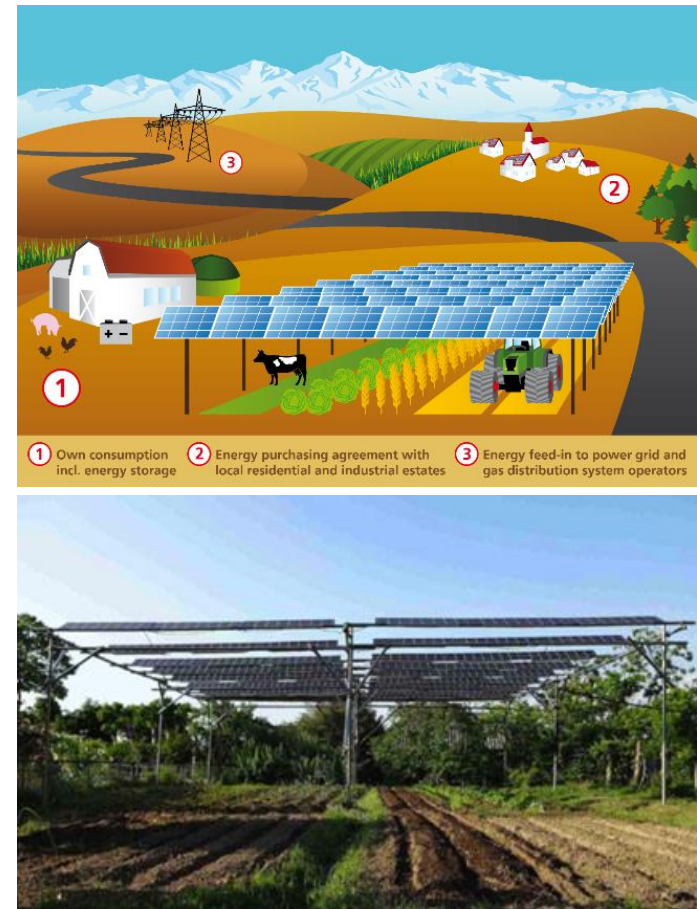

4.- Double Use of Land– Agriculture and Photovoltaics

Project Agro-PV

LAMPA	CURACAVÍ	EL MONTE
		
		
<ul style="list-style-type: none"> -pequeños productores formalizados como empresa -Consumo frío, packing, invernadero, casas y bombas -hortalizas verdes 	<ul style="list-style-type: none"> -Pequeños productores formalizados como empresa -Consumo frío, packing, casas, bombas y oficinas -Hortalizas verdes, papas, zapallo, repollo, brócoli, coliflor, Kale 	<ul style="list-style-type: none"> - Cinco grupos familiares de 3-4 personas cada uno. -1,5 Ha en promedio por persona. -Consumo hogares, emprendimiento de criadero de gallinas con incubadora. -Cebolla, papa y porotos

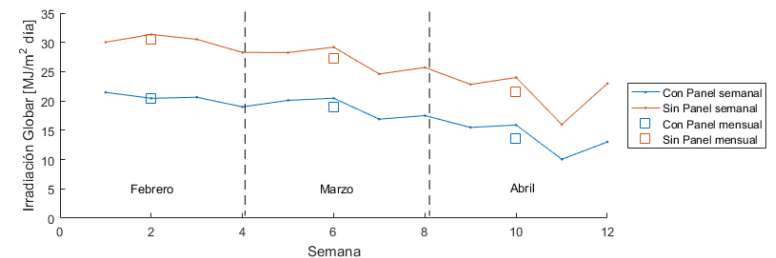
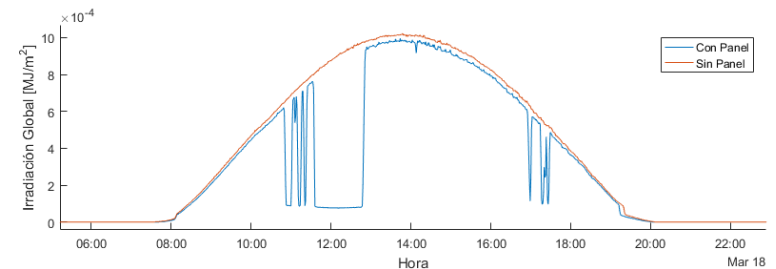
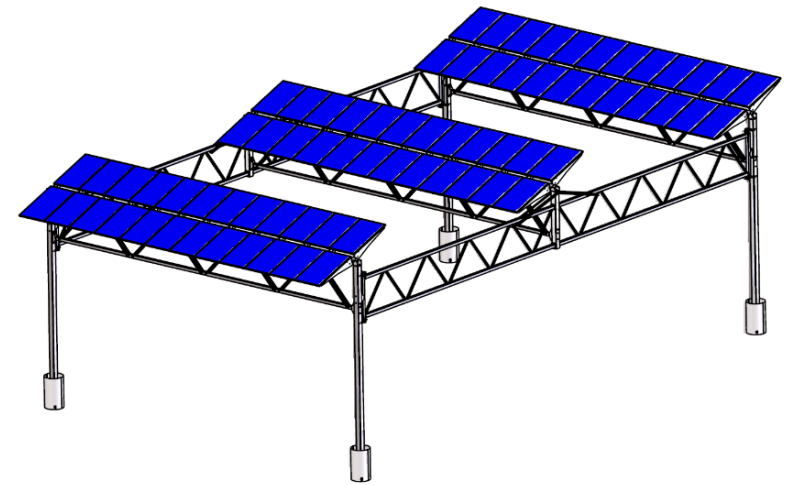

4.- Double Use of Land– Agriculture and Photovoltaics Project Agro-PV

North Orientation

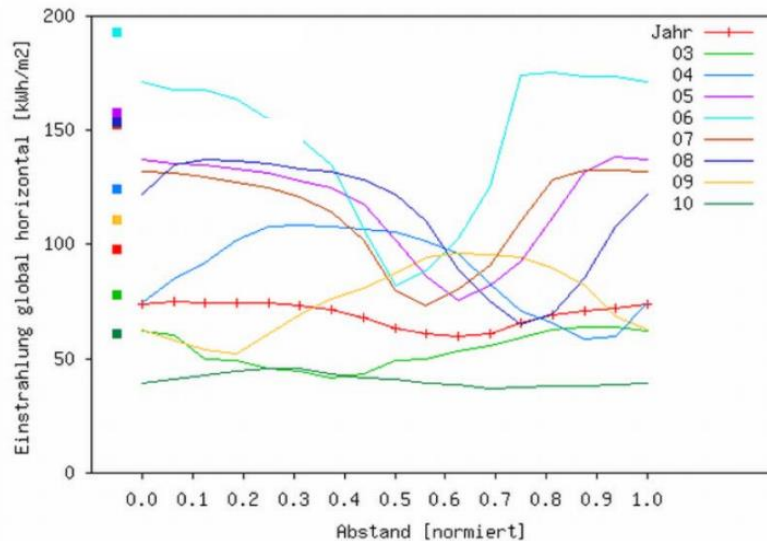

Norwest Orientation

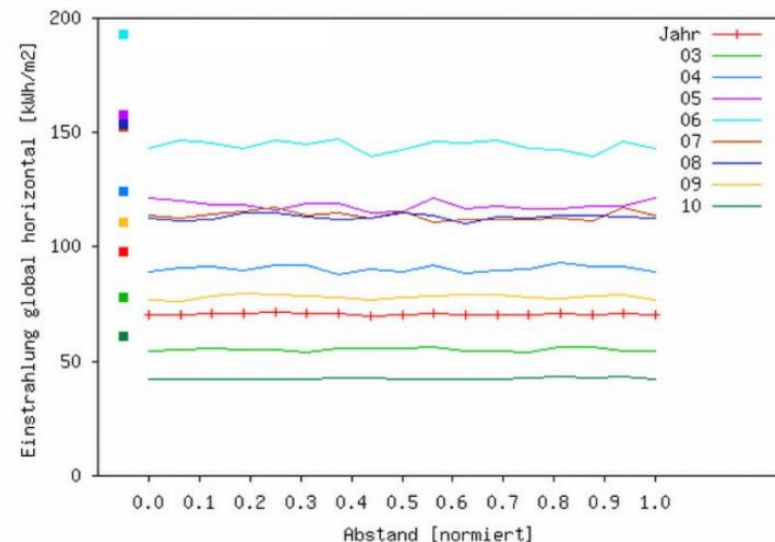

Homogeneous distribution of radiation underneath APV possible

- Sufficient radiation during vegetation phase of crops feasible
- Electricity losses compared to South orientation are low: -5 %
- Peak-load shifted into morning or afternoon hours due orientation

4.- Double Use of Land– Agriculture and Photovoltaics

Project Agro-PV

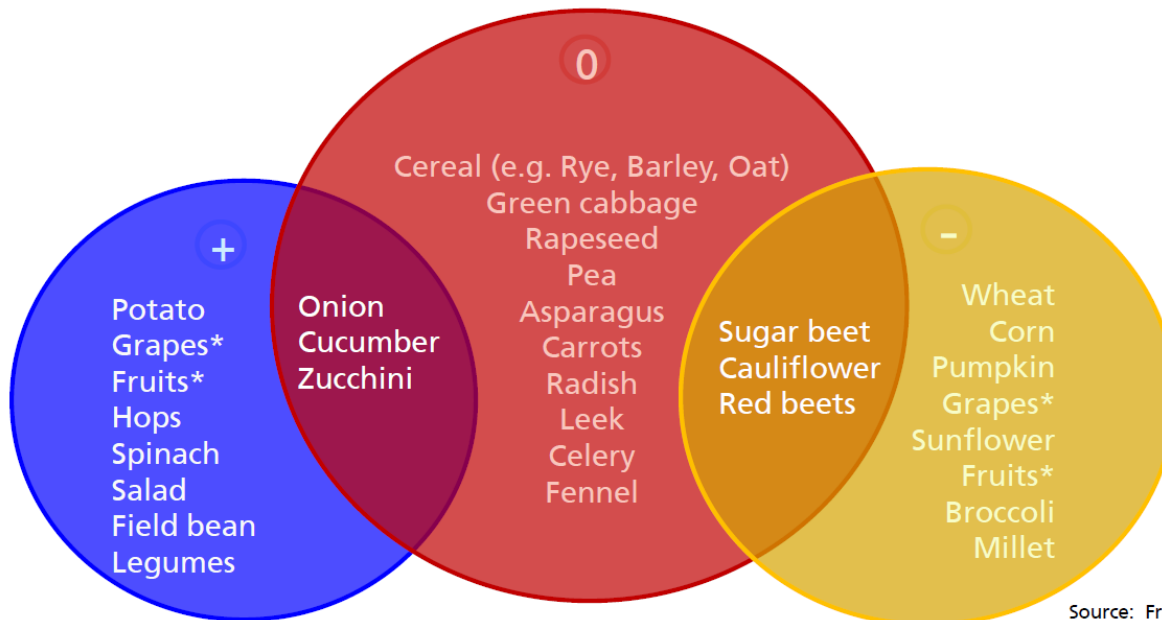

Source: Fraunhofer ISE

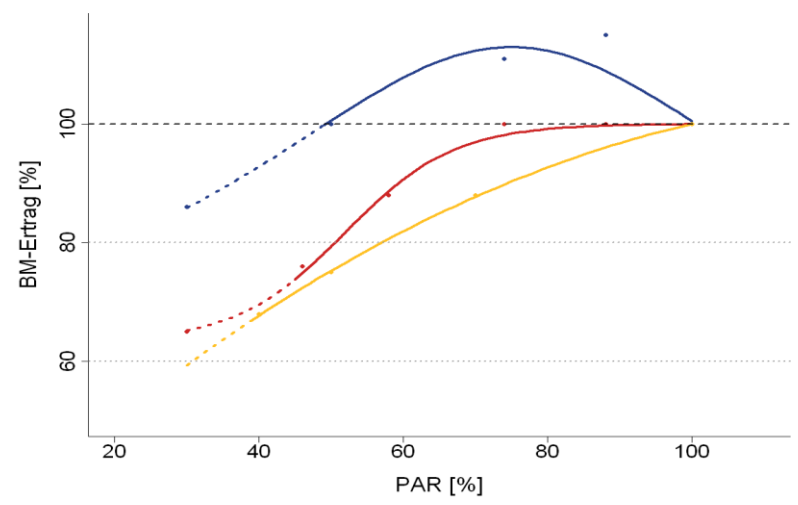

Santiago



2.269 kWh/m2/año

Frankfurt



1.289 kWh/m2/año

4.- Double Use of Land– Agriculture and Photovoltaics

Project Agro-PV

- Monitoring under photovoltaic panels:
- Horizontal global irradiation sensor
- Temperature and humidity sensors
- Soil moisture sensors at different depths (10, 30 and 50cm)

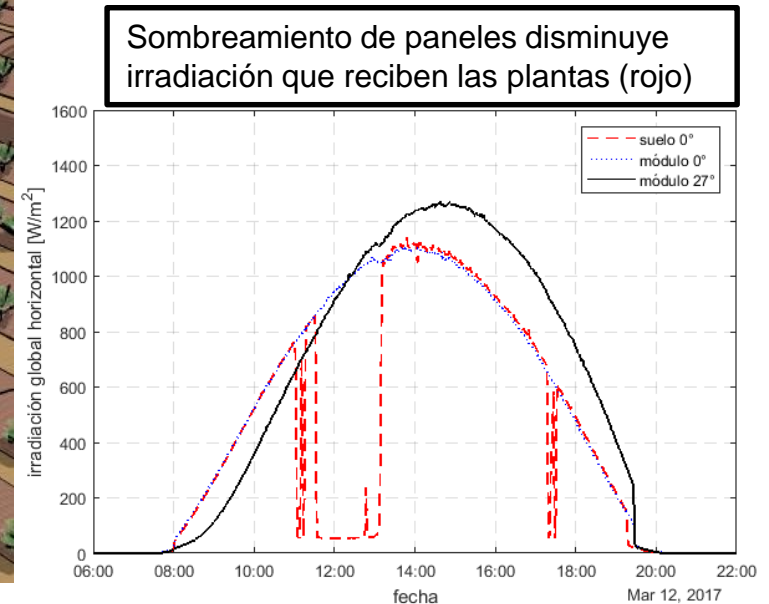

Lampa



Results

Lettuce crops

There is no impact of the panel on the lettuce crop, presenting a neutral response to the shading that occurs due to the effect of the Agrofotovoltaic system (APV).

	Localidad Lampa	
	Sin panel	Con panel
Tiempo de plantación a cosecha (Primer floreo)	60 días	
Peso promedio comercializable según criterio del productor	80 a 100 gr	
Peso promedio obtenido	99 gr	92 gr

Curacaví



Results

broccoli crops

The results show a negative impact on the crop due to the effect of the partial shading generated by the panels. The weight of the broccoli in the panel treatment showed a 28.8% decrease with respect to the weight reached in the control treatment.

	Localidad Curacaví	
	Sin panel	Con panel
Tiempo de plantación a cosecha (Primer floreo)	65 días	
Peso promedio comercializable según criterio del productor	800 gr a 1 Kg	
Peso promedio obtenido	379 gr	270 gr

5.- Now-Casting Project SkyCameras

Private funding for nowcasting in PV plants, based on a UCSD development.

- Image processing of sky photos
- Algorithm development for nowcasting prediction

Expected results

- Accurate nowcasting (5-15 min prediction)
- Stabilising a national net of nowcasting for the National operator



7.- FONDEF IDEAS: Autonomus Sistem for maintenance based in conditions (CBM) for PV power plants.

Develop and implement a novel methodology for monitoring conditions for predictive analysis in photovoltaic plants based on intelligent analysis of real-time images.

Opportunity: 1- Fault management

Opportunity: 2- Soiling Management

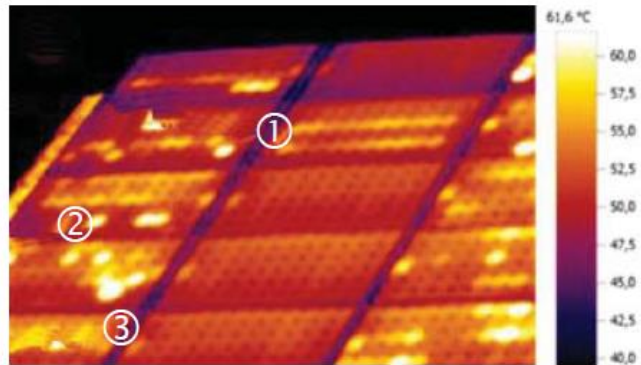

8 Membrane Distillation

Economical tool and Prefeasibility

- For membrane distillation the energy consumption is nearly not dependent on salt content of brine – contrary to reverse osmosis
 - Use for sea and brackish water desalination
 - Up-concentration of salt brine
- Use of low temperature waste heat 60-80°C (diesel gens, power plant) or solar heat
- Estimation of the investment and economy depending on plant size, salt concentration, energy costs

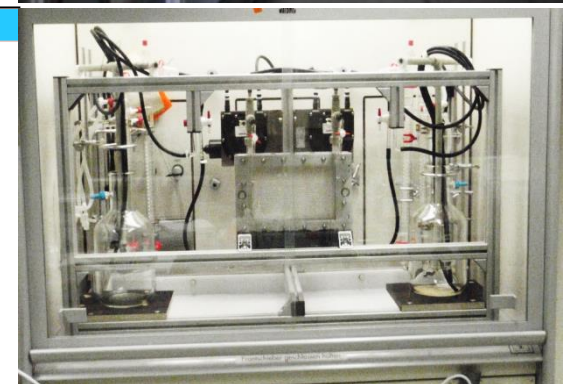
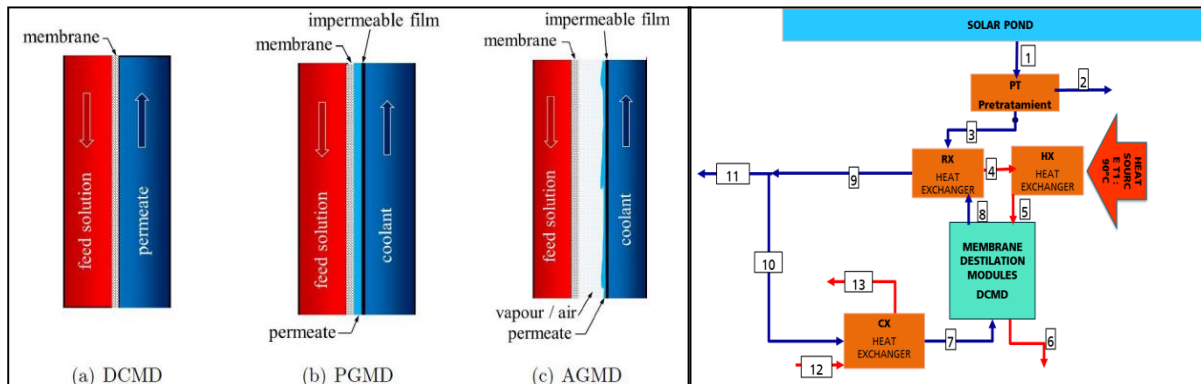

9. Desalación Solar: *Multi Effect Distillation*

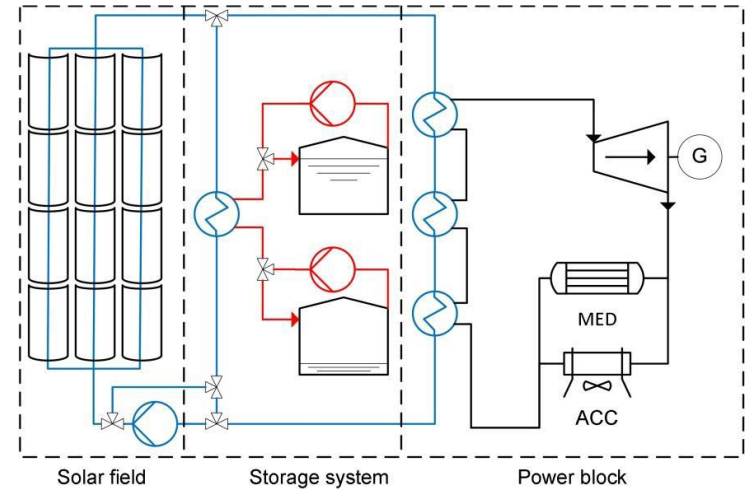
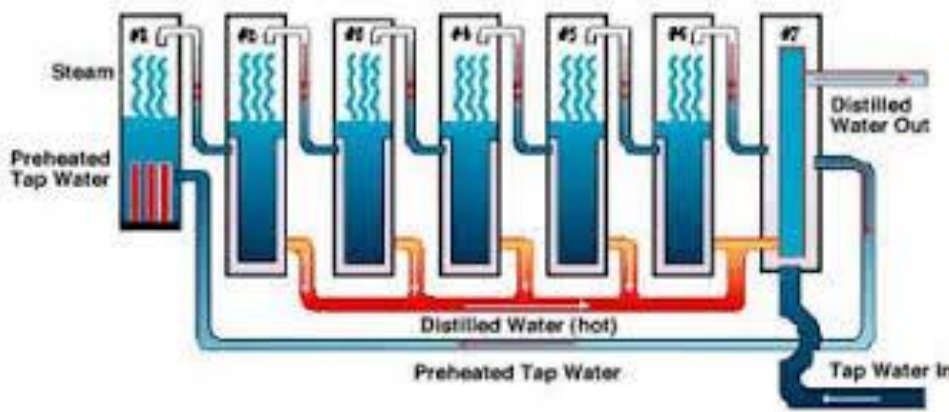

Path A (Antofagasta)

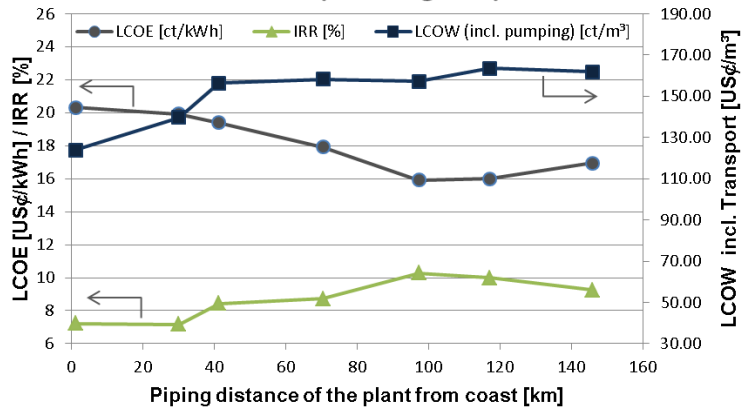

Path C (Copiapó)

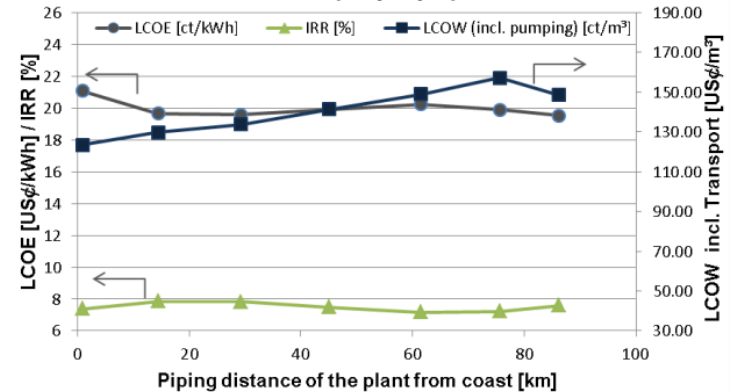

SolarPaces 2017 Conference: CSP MED

Combining concentrating solar power with multiple effect distillation at inland locations - An economically viable option for Northern Chile?

Raymond Branke^{1, a)}, and Thomas P. Fluri^{1, b)}, and Patricio Valdivia Lefort^{2, c)}
(Use the Microsoft Word template style: *Paper Author*)

¹*Fraunhofer Institute for Solar Energy Systems ISE, Heidenhofstrasse 2, 79110 Freiburg, Germany.*

²*Fraunhofer Chile Research Center for Solar Energy Technologies (CSET).*

^{a)}Corresponding author: raymond.branke@ise.fraunhofer.de

10 Solar Hydrogen for the Mining Industry

CORFO CALL: “Adaptación de la operación de equipos móviles mineros de diésel a hidrógeno, mediante celdas de combustibles”

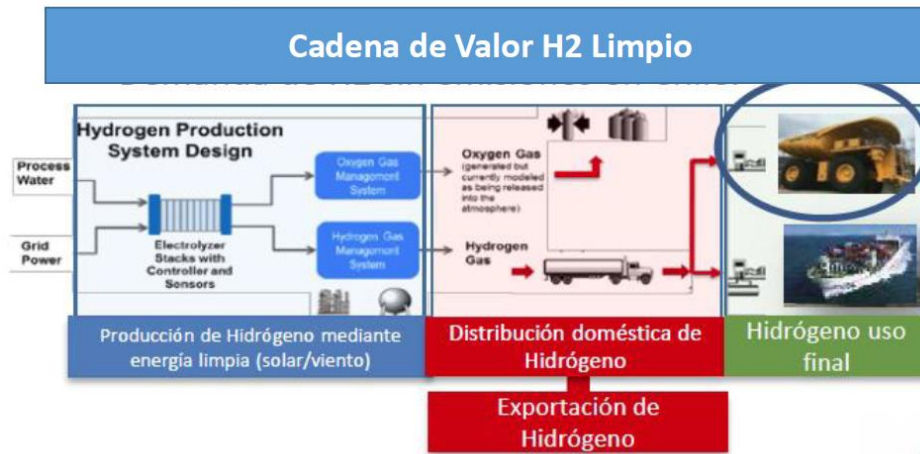

10 Solar Hydrogen for the Mining Industry

CORFO CALL: “Adaptación de la operación de equipos móviles mineros de diésel a hidrógeno, mediante celdas de combustibles”



[SOBRE CORFO](#) [CONVOCATORIA LITIO](#)

[CONTÁCTANOS](#) [INGRESAR](#)

ESTÁS EN: **CORFO NACIONAL**

[INICIO](#) [ÁREAS DE TRABAJO](#) [PROGRAMAS Y CONVOCATORIAS](#) [ESPACIO COLABORATIVO](#) [SALA DE PRENSA](#) 

Programa Tecnológico: Adaptación de la Operación de Equipos Móviles Mineros de Diésel a Hidrógeno, mediante Celdas de Combustibles

CAPACIDADES TECNOLÓGICAS

Postulaciones Abiertas

10 Solar Hydrogen for the Mining Industry

CORFO CALL: “Adaptación de la operación de equipos móviles mineros de diésel a hidrógeno, mediante celdas de combustibles”

„Water will be the coal of the future. Energy of tomorrow will be water that was split by electricity“

(Jules-Gabriel Verne, 1828 – 1905, Mysterious Island , 1874)

SIEMENS
Ingenuity for Life

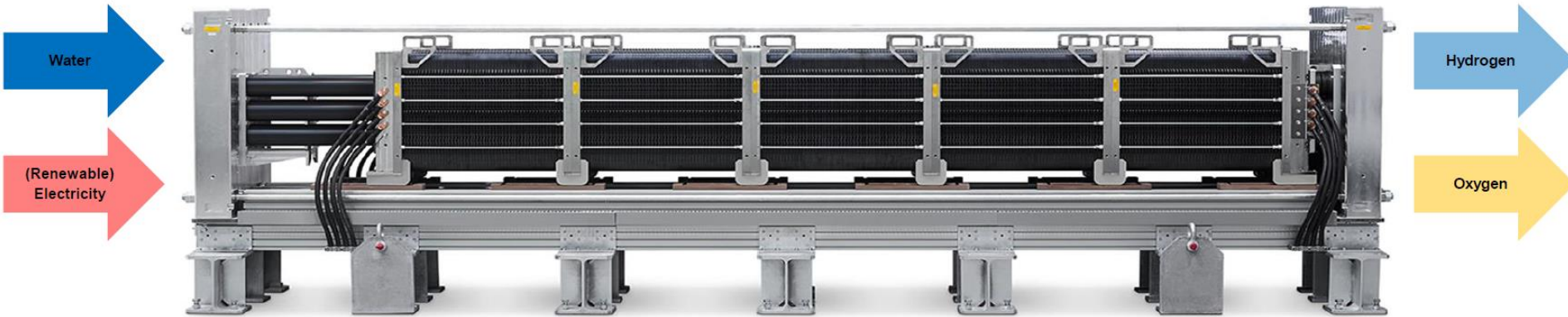

Dr. Markus Böhm Sales Manager - Siemens

10 Solar Hydrogen for the Mining Industry

CORFO CALL: “Adaptación de la operación de equipos móviles mineros de diésel a hidrógeno, mediante celdas de combustibles”

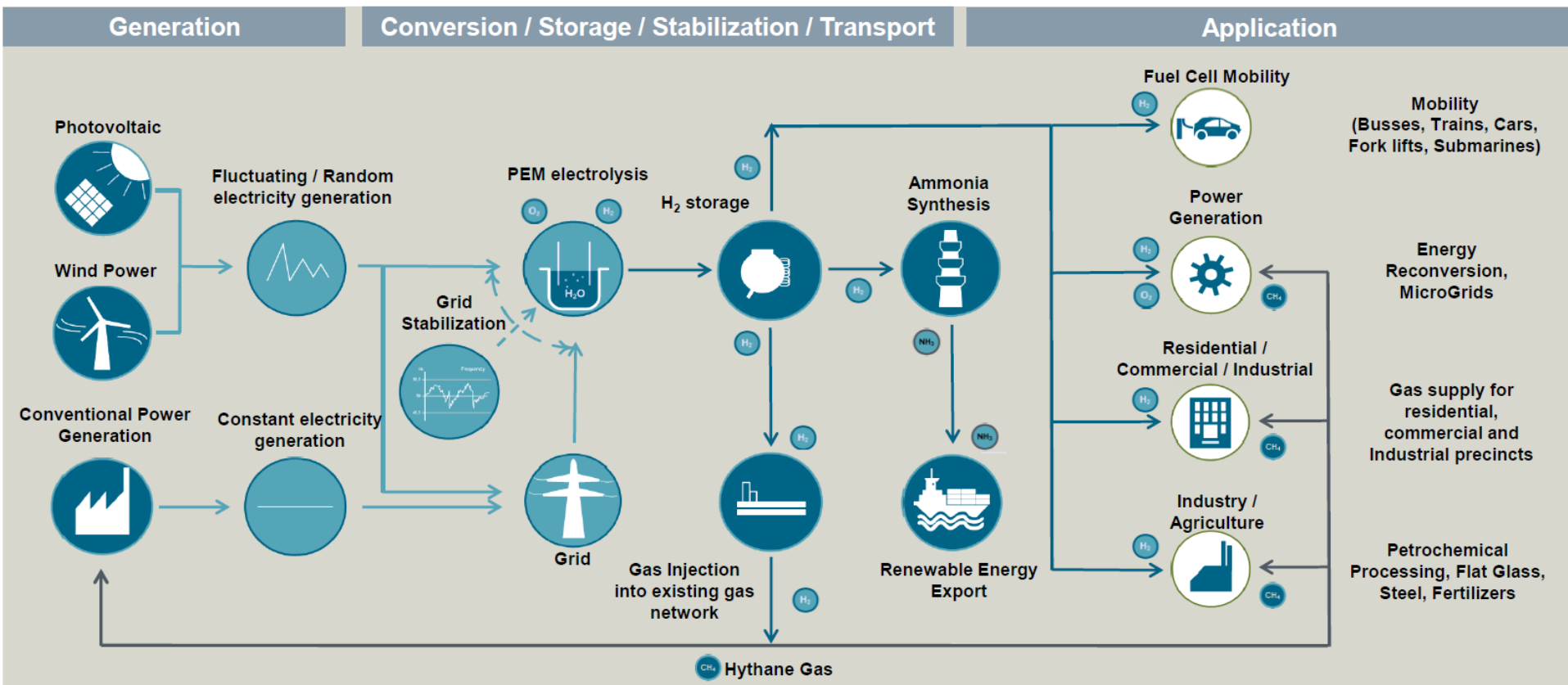

Fuel Cell Plug-In Shuttle Bus.



Fuelcell-Hybrid Mine Loader (LHD). March 2004-
December 2008

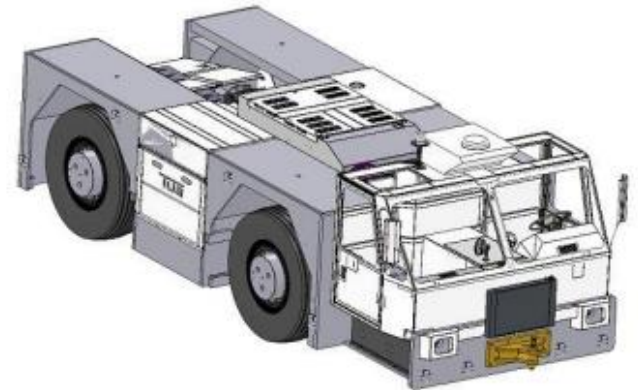

Fuel Cell Plug-In Hybrid Electric C-17 Tow Tractor



New Photovoltaics Technologies



Corfo dio a conocer la adjudicación del programa para el “Desarrollo de tecnologías para la industria de energía solar fotovoltaica en Chile”. Este proyecto, pionero en el país, financiará la creación de un consorcio cuyo principal objetivo será desarrollar tecnologías que se adaptan a las condiciones únicas del Desierto de Atacama; alta radiación y clima árido extremo, para así impulsar el desarrollo de la industria de energía solar en Chile.

Programas Tecnológicos de Desarrollo de Tec. de E. Solar Fotovoltaica para Climas Desérticos y Alta Radiación

CAPACIDADES TECNOLÓGICAS

Atacama Module (AtaMo): a long lasting, powerful, highly efficient module for desert applications



Figure 1: Old standard module (left) in comparison with bifacial glass-glass module in front of a mirror (right). Image: MegaCell.

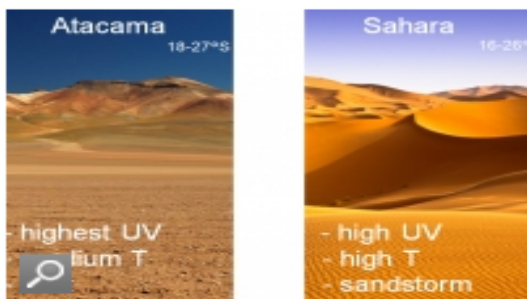

Figure 2: Different deserts – different conditions.



For 30 years c-Si PV module production has not incorporated many changes and developments from the R&D labs. The standard modules still consist of c-Si cell strings soldered and laminated in between EVA, white backsheet and front glass. The edges are sealed with silicone and framed with aluminum. On such modules product guarantees of 10 years and 80% power guarantees for 20 years are given. In our *Photovoltaics International* article (“Module technologies for high efficiency solar cells: The move away from powerful engines in old-fashioned car bodies”) we discussed the fact that these days, innovations like back contact, glass-glass and also bifacial modules are now slowly entering the PV the market.

Not only do standard modules look almost identical to ones from 30 years, they were also mostly all constructed and the components optimised for European conditions. Besides temperature cycling and damp heat testing, certification institutions also check how modules

Blogger



Dr Radovan Kopecek

Dr Radovan Kopecek is one of the founders of ISC Konstanz. He has been working at the institute as a full time manager and researcher since January 2007, and is currently the head of the Advanced Solar Cells department.

Blogger



11.- Atacama PV Module – AtaMos Tec Project

Solar Program:

- Production of PV modules in Chile
- 10 year program
- 12 MMUSD Subsidy
- 3.5 MMUSD pecuniary contribution
- 2 MMUSD In kind contribution.



12.- New Technologies

Project Bifacials in different environments



Advantages

- Additional gain
- Vertical installation
- Soiling
- LCOE

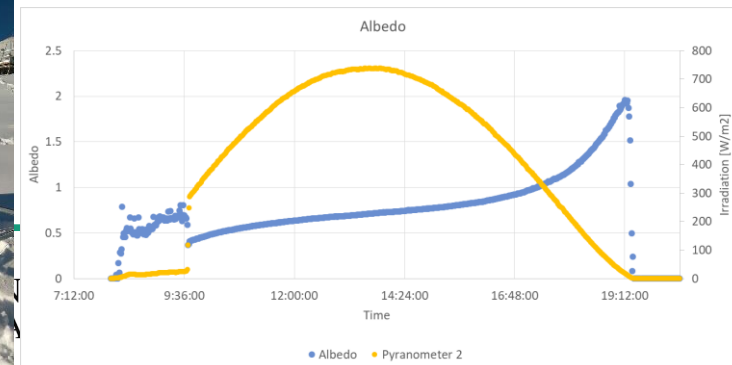

13.- Concentrated PV

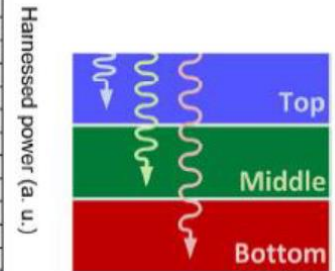
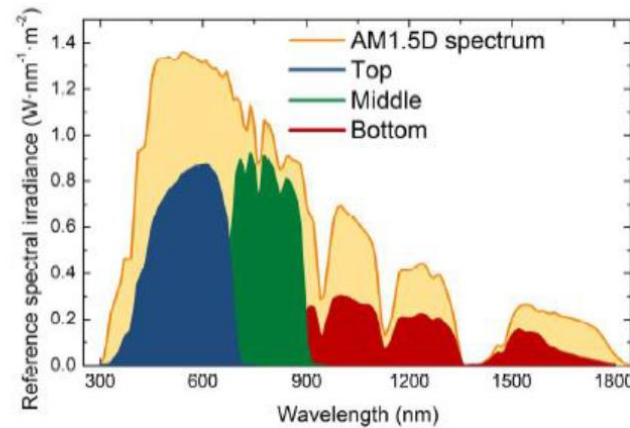
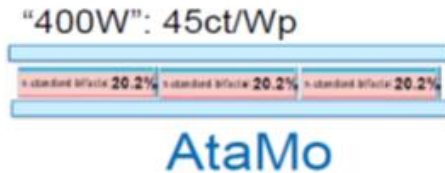
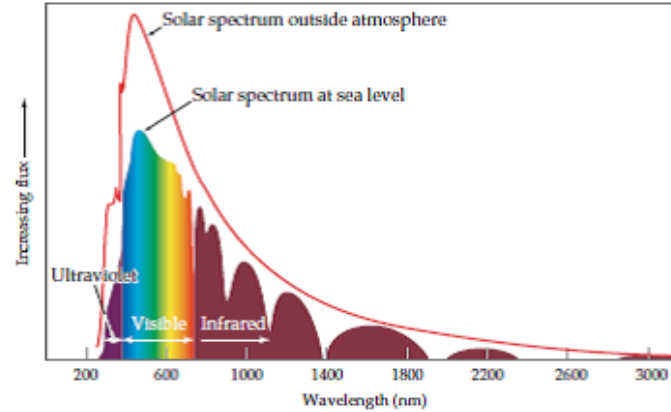
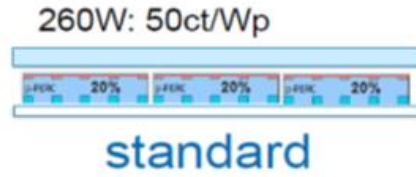

13.- Concentrated PV



2 strategies to reduce semi-conductor material

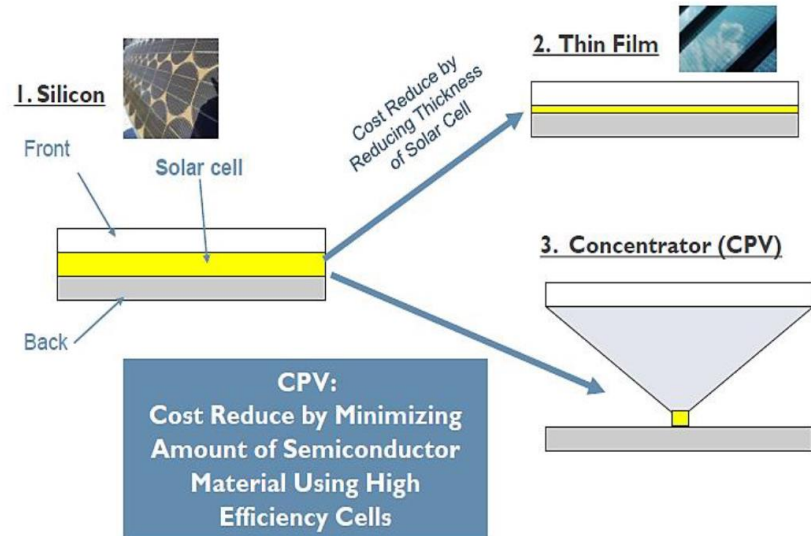

13.- Concentrated PV

Levelized cost of energy for solar technology

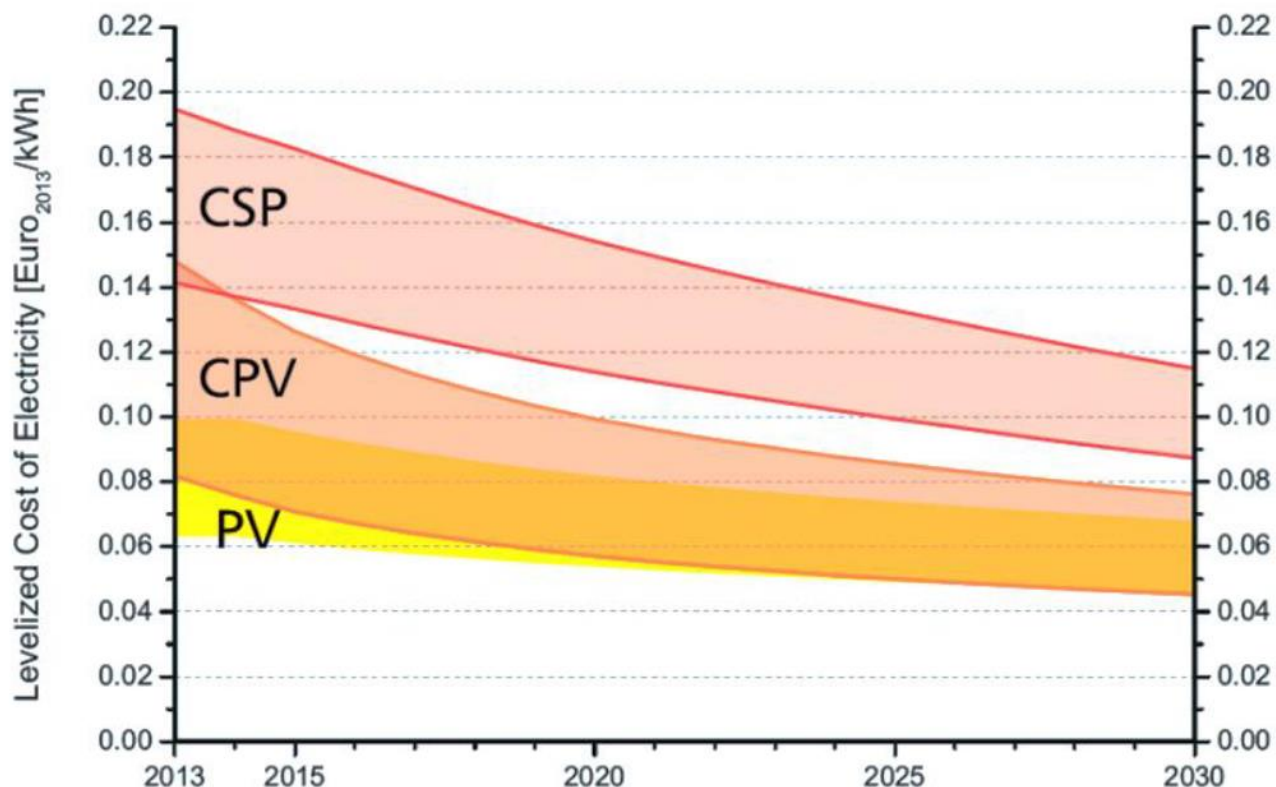

[1] Levelized Cost of Electricity Renewable Energy Technologies, Fraunhofer report

13.- New Technologies

Project Bifacials in different environments

Best Research-Cell Efficiencies

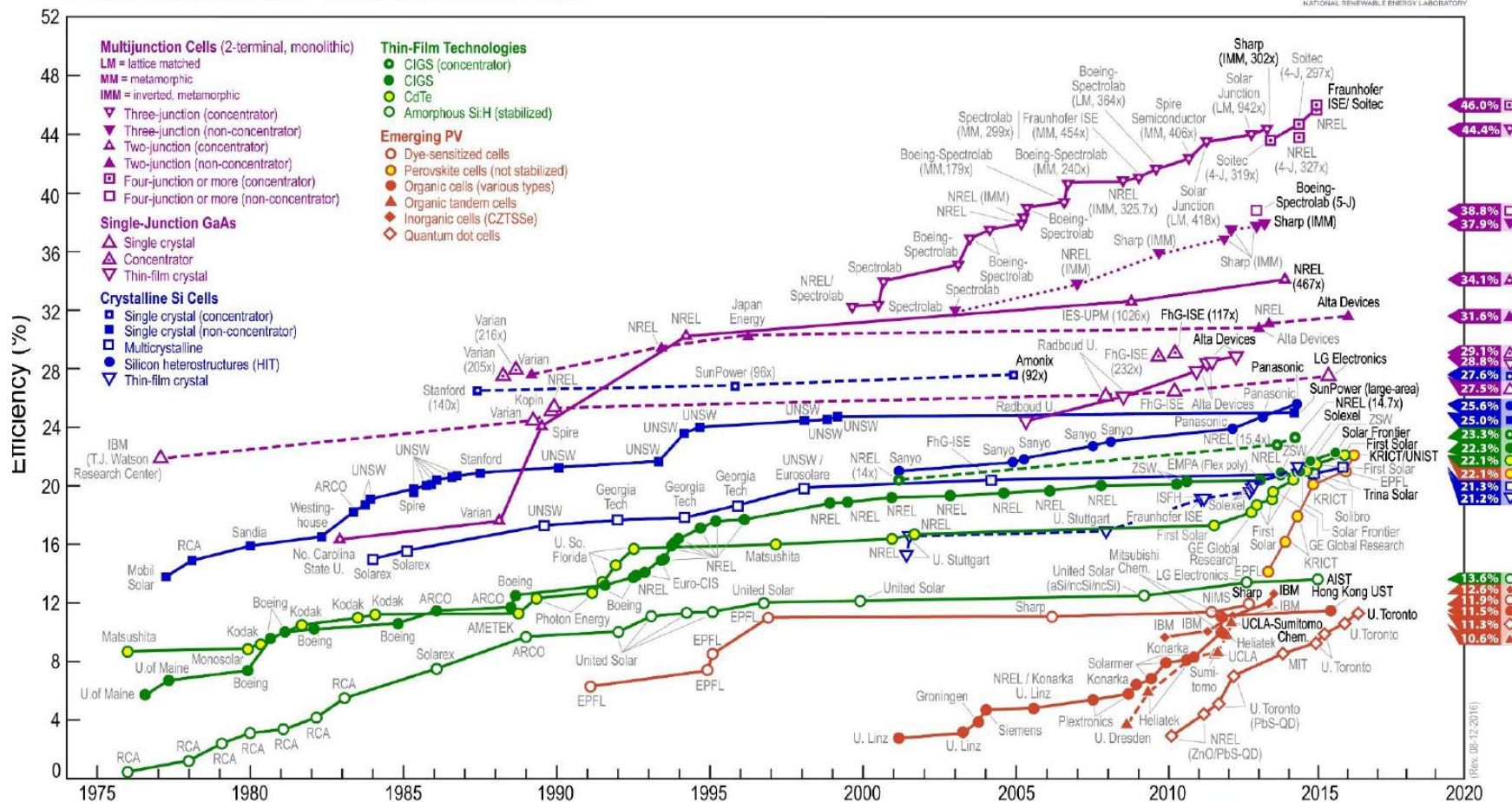

For a Solar Future of Chile

Contact:

Prof. Dr. Patricio Valdivia Lefort

patricio.valdivia@fraunhofer.cl

patricio.valdivial@usm.cl

www.fraunhofer.cl

www.usm.cl